

FROM WAVE PARKS
TO WADING POOLS,
WE HAVE A NEX-GEN[®]_{pH}
SYSTEM TO MEET
YOUR NEEDS.



ChlorKing's NEX-GEN_{pH} on-site chlorine generators are leading the way to better, safer water. Their unique, forward-thinking design generates liquid chlorine from salt that is stored on site and uses the pool as the source water for the product. NEX-GEN_{pH} eliminates the need for storing large amounts of chlorine and doesn't generate the odors associated with traditional chlorine. Any of the NEX-GEN_{pH} systems can be fully customized to meet your needs and are easy to install, maintain and operate.

The NEX-GEN_{pH} 40

The ChlorKing[®] NEX-GEN_{pH} 40 is a stand-alone, on-site chlorine generator capable of producing 48 lbs. of pH neutral equivalent chlorine per 24 hours. The unique design uses swimming pool water to feed the generator and distribute chlorine to the pool as needed. Up to 6 bodies of water can be sanitized with one NEX-GEN_{pH} system using our venturi feed systems and can be used in conjunction with any ORP/pH controller. This product requires no salt in the swimming pool and will not raise TDS levels as with other chlorine generators. Hydrogen, the by-product is safely vented to atmosphere through a 2" (5cm) PVC pipe on top of the production tank.

Specifications

- Touch-screen display
 - › Size 5" x 4" (12cm x 10cm) color display
 - › Resistive touch membrane overlay
- Built in safety sensors
 - › Air, water, pressure, & level sensors
 - › Power supply
 - › 100 amp 24v DC water-cooled
- Electrode stacks
 - › 2-24 lb, 15,000 hr forward polarity in clear housing
- Operating temperature - power supply cooling
 - › 35°F (2°C) to 115°F (46°C) air temperature
 - › 40°F (4°C) to 104°F (40°C) water temperature

- Pool source water
 - › Up to 94°F (34°C) water temperature
- Electrical specifications
 - › Max primary amps – (32)
 - › Voltage / Hz – (208-240v 50/60Hz single phase)
 - › Breaker required – (60 amp)
- Skid dimensions & weight
 - › 48" (121cm) L x 28" (71cm) W x 68" (172cm) H
 - › 48" (121cm) L x 22" (55cm) W x 40" (101cm) H (salt feeder)
- Plumbing requirements
 - › 2" (5cm) inlet and outlet requiring 80 gpm (302 Lpm)
 - › 2" (5cm) outlet for hydrogen removal to atmosphere
 - › Maximum NEX-GEN venturi return line pressure (including pool return line) - 25psi



Main Features

- On-site chlorine generator capable of producing 48lbs. (equivalent to 48 gal of 12% bleach) per 24 hrs.
- Process uses swimming pool water to produce sodium hypochlorite (no fresh water added)
- No salt is required in the pool
- pH neutral chlorine produced
- Programmable touch-screen with auto correct features
- Skid mounted on wheels for easy installation
- Water-cooled power supply

Applications

- Commercial swimming pools
- Water-parks
- Wave and surf riders

Order Information

- Product code: NEXGEN 40

NEX-GEN[®] pH 40 DIMENSIONS & TANK LAYOUT

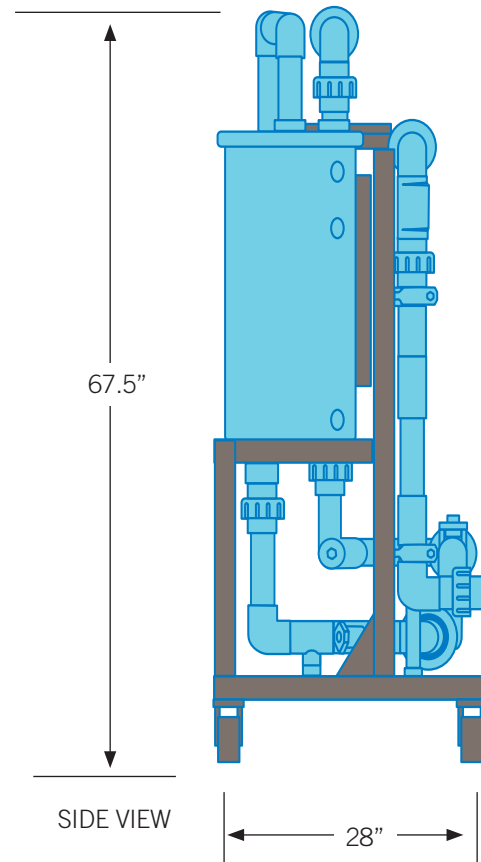
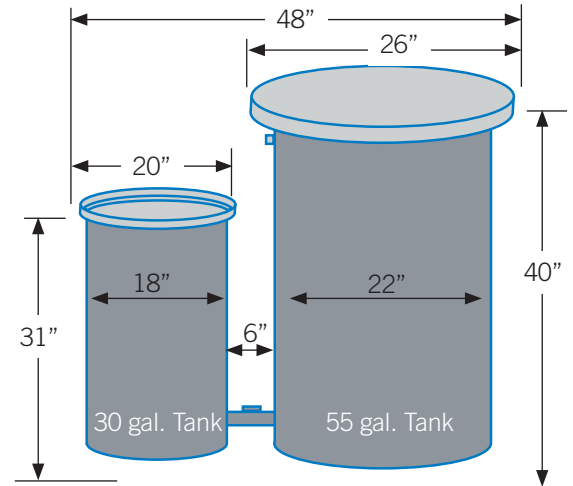
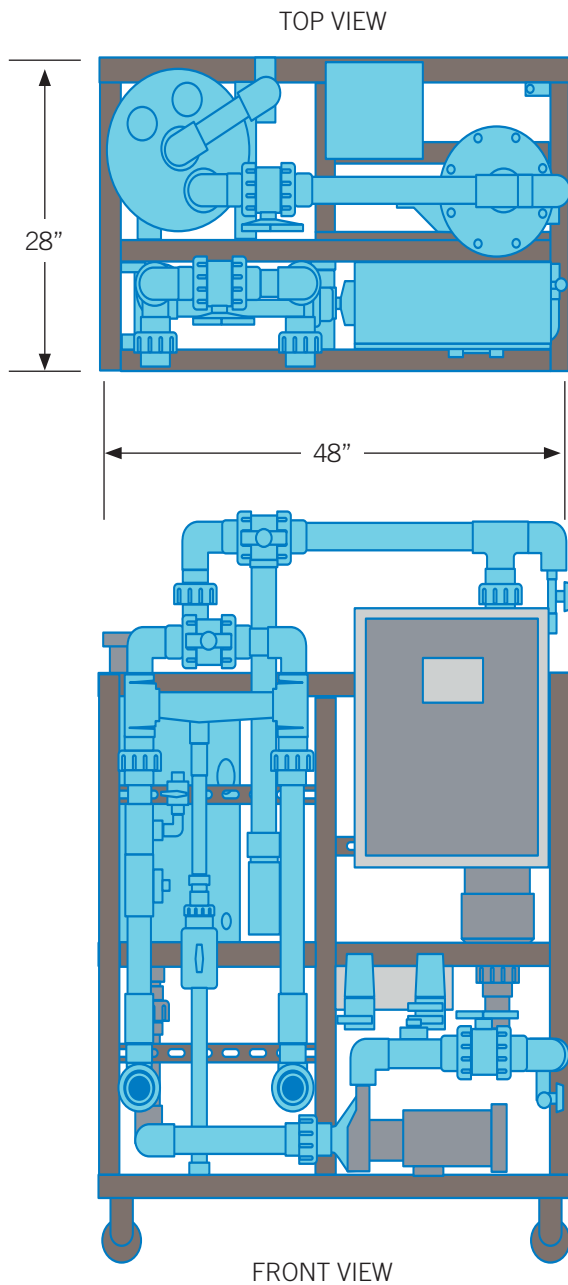

ChlorKing pioneered on-site chlorine generating technology in the 1970's. Realizing the potential for swimming pools and commercial applications, the company began generating "ultimate water" with simple, yet highly advanced technology. Today, ChlorKing[®] leads the way in commercial saline chlorination and is consistently seeking new frontiers in sanitizing solutions including ultraviolet light technology and their NEX-GEN[®] pH onsite chlorine generators. These environmentally friendly solutions are changing the way we treat H₂O.



Safer water through smarter technology.

Salt Chlorination Systems • Ultraviolet Light Systems • Mixed Oxidant Systems

ChlorKing Inc. 6767 Peachtree Industrial Blvd Norcross GA 30092 sales@chlorking.com 800.536.8180 chlorking.com