

HYPO-mini

Producing a Hypochlorous solution on-site has never been easier



The HYPO-mini

The HYPO mini is a compact entry level offering for generating hypochlorous onsite. Compact does not mean weaker. The HYPO mini packs a heavyweight punch! The HYPO mini rests on the foundation of the ChlorKing 20 year tried and tested electrolytic cell. Customers can be assured they are getting a powerful hypochlorous solution at either 200 or 500ppm concentration in as little as 8 minutes! There is a 3 limited warranty on the HYPO mini and 2,000 hours of life on the cell. At just 8 cents to produce a gallon of hypochlorous ... no brainer! The HYPO mini is a thing of duty and a very hard worker. Thank you for your business and we look forward to working with you.

Uses

- Bacteria inactivation
- Virus inactivation
- Cleaning food surface preparation areas
- Tile floor cleaning
- Any situation where sodium hypochlorite or calcium hypochlorite have traditionally been used.

Dimensions and weight	
Length x Width x Height (tank & stand)	10" x 10" x 15"
Length x Width x Height (power supply)	10.5" x 4" x 7.5"
Weight (tank & stand / power supply)	8 lbs. / 4.5 lbs.

Shipping dimensions and weight	
Length x Width x Height (Box)	15" x 15" x 20"
Weight	17 lbs.
Harmonized tariff code	8421.21.00

Electrical requirements	
Max AC primary amps	0.6amps @ 110v
Voltage / Hz	110-240v 50/60Hz
Phase	Single
Breaker required	15 amp

Generator performance	200ppm FAC	500ppm FAC
Water softener required	No	No
Hypochlorous acid produced	2 gallons per batch	
pH of solution	5.5 - 6.5	
FAC of generated solution	>200ppm	>500ppm
Estimated salt usage	2 tablespoons per batch	
5% vinegar used (tablespoons per batch)	2 tablespoons	4 tablespoons

Specifications	
Power supply	8amp 12v DC
Electrode stack (cell)	2,000 hour
Operating temperature (Air)	45°F - 115°F (7°C - 46°C)
Operating temperature (Water)	50°F - 80°F (10°C - 26°C)

Dimensions

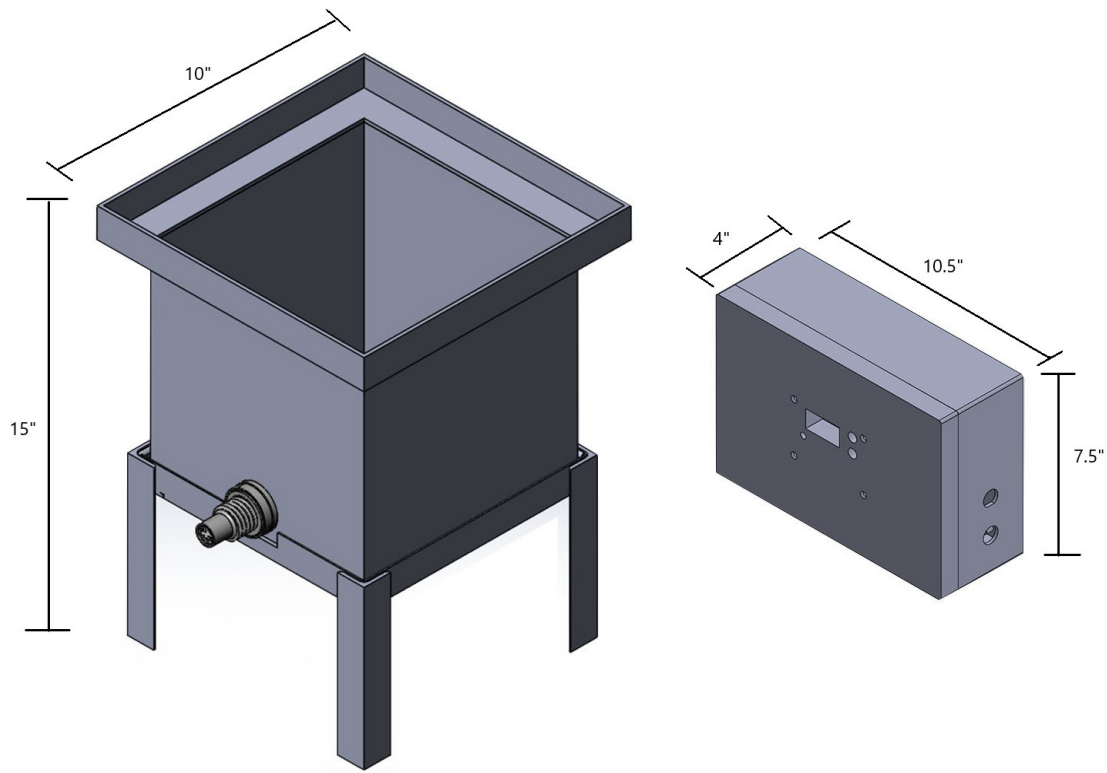

ChlorKing pioneered on-site chlorine generating technology in the 1970's. Realizing the potential for swimming pools and commercial applications, the company began generating "ultimate water" with simple, yet highly advanced technology. Today, ChlorKing® leads the way in commercial saline chlorination and is consistently seeking new frontiers in sanitizing solutions including ultraviolet light technology and their NEX-GEN® pH onsite chlorine generators. These environmentally friendly solutions are changing the way we treat H₂O.



Safer water through smarter technology.

Salt Chlorination Systems • Ultraviolet Light Systems • Mixed Oxidant Systems

ChlorKing Inc. 2935 Northeast Parkway Atlanta, GA 30360 sales@chlorking.com 800.536.8180 chlorking.com